

THE MARITIME LAW ASSOCIATION
OF AUSTRALIA AND NEW ZEALAND

13th Annual Meeting and Conference

15th - 22nd November, 1986, Marriott Hotel
Maui, Hawaii, U.S.A.

Developments in Carriage of Sensitive/Perishable Cargoes

J. R. LOVEGROVE

The Shipping Corporation of New Zealand Ltd

INTRODUCTION

The first shipment of refrigerated meat from New Zealand to the United Kingdom took place over 100 years ago. This and other early shipments laid the basis in New Zealand and Australia for a pastoral farming industry providing wool, beef and sheep meat, dairy products etc to the United Kingdom and other European countries. It followed that the countries purchasing these goods provided most, if not all, services required to support these agricultural enterprises. The services include shipping, insurance and finance etc.

During the last decade various changes have been forced on Australia and New Zealand. The emergence of the European Economic Community has restricted access to the United Kingdom and other European markets. The world economy and the effects of the oil crisis have played their part in reshaping our future as far as agricultural exports are concerned.

The traditional exports of meat, wool and dairy products are still major contributors to overseas earnings. However, Government and private sector industries in both countries are urgently involved in creating changes to trading patterns.

It is of vital importance for New Zealand and Australia to be able to trade economically with countries that share their location on the rim of the Pacific Ocean, South East Asia as well as the more distant markets in Europe, Middle East and the East Coast USA. To take advantage of the opportunities in these market places there will be a need to alter traditional agricultural farming practices to meet the needs of these countries which vary in their individual requirements.

Changes in land use have taken place during the last ten years. Production of a variety of horticultural products is now underway and these commodities will emerge in larger volumes as this decade draws to a close.

More imagination is being used in the manner in which the traditional products are marketed involving fresh meat, fish and dairy products.

These changes will create challenges to the transportation industry and support services such as insurance in the years ahead.

ANTICIPATED CHANGES IN MARINE TRANSPORT SERVICES

There is a growing need throughout the world for fresh fruits, vegetables and meats. For several reasons there is a preference

for fresh commodities compared to the same product in a preserved form (i.e. frozen, dehydrated etc).

New Zealand and Australia are well placed to respond to "fresh product" needs especially when seasonal displacement and climate are taken into account. However, the distances from major international markets create considerable "physical distribution" problems when transporting highly sensitive/perishable commodities.

Often when developing a new commodity and/or market, airfreight services are used. However, as volumes increase and the need for lower freight rates becomes apparent the continued growth of any commodity/market combination will heavily rely on the availability and quality of a seafreight service.

Whilst the changes from traditional frozen, hardy products is only just beginning indications are that the trend will increase. Unless seafreight services are made available to meet the needs of these more perishable commodities along, with finance and insurance services, market growth could become limited.

FORECASTING THE PROBLEMS OF CHANGE

During the late 1970's work commenced in New Zealand to try to identify what problems will exist when large quantities of perishable cargo are required to be shipped by sea. The work was undertaken by The Shipping Corporation of New Zealand and the Auckland Industrial Development Division of the New Zealand Department of Scientific and Industrial Research.

In the first instance commodities were divided into groups. These groups are shown in the following chart.

HORTICULTURAL COMMODITIES

POST HARVEST LIFE - GROUPINGS

1. Good Keepers

Not Temperature Reliant

Onions - Potatoes
Squash - Garlic
Etc

2. Good Keepers

Temperature Reliant

Apples - Pears
Kiwifruit
etc

3. Average Keepers

Temperature Reliant

Stonefruit - Cut Flowers
Tamarillos - Blueberries
Avocados - Melons
etc

4. Poor Keepers

Temperature Reliant

Berryfruit - Cut Flowers
Etc

GROUP 1

Commodities that are not temperature reliant require good

ventilation to dissipate the products of respiration and to avoid surface condensation.

It was found that these commodities are reasonably well provided for as far as sea freight is concerned. However, restrictions were identified when shipping onions to the European market. It has been found that by providing positive ventilation in general purpose containers at 30 air changes per hour (based on the empty volume of the container) satisfactory results can be obtained.

The forced ventilated container also provides suitable conditions for many other products that are shipped by sea and suffer problems with condensation. These containers are now available from Australia and New Zealand carrying considerable volumes each year.

GROUP 2

Commodities such as apples, pears, kiwifruit etc that require temperature control but are reasonably hardy are well catered for within current marine transportation systems. Few transportation limitations could be established that would restrict the development of markets for these products. Over 90% of export revenue was derived from this group.

GROUP 3

When the survey was carried out in New Zealand it was this group of commodities that were unable to be shipped by sea for any distance other than perhaps between New Zealand and Australia. Typically these products have a post harvest life, under good

refrigeration, of about 3 weeks. Generally speaking the time the product is in the container between say Melbourne, Sydney or Auckland and most West Coast USA, Japan, South East Asia destinations is about 21 days. This made the transport of these products by sea very marginal if not impossible with predictable results. In 1982 New Zealand's horticultural exports of about \$220 million included less than 5% contribution from these groups and without exception all products were being airfreighted.

Much of the changes in land use, aimed at increasing horticultural export revenue involved heavy plantings of the products in this group especially stone fruit, asparagus, blueberries, avocados, tomatoes, mango etc.

It was therefore in this area that most efforts were made to improve marine transport services.

GROUP 4

The last group of products to be considered are of a highly perishable nature and unlikely to be carried long distances by sea with any degree of success. These products are typically the soft berry fruits which require precise post harvest handling and rapid shipment by air to overseas markets. It was concluded that the probability of these products being carried by sea over long distances in a fresh form is low.

FACTORS OF DEVELOPMENT

There are two separate but related areas of development that need

to be considered when discussing the changes that have taken place in the carriage of sensitive/perishable cargoes.

Firstly changes have occurred from an engineering point of view with the equipment that is used by the marine carrier to create the environmental conditions required for the cargo. Changes have taken place in both conventional ships and containers. I will restrict my comments in this paper to the changes associated with containers.

Additionally it should be noted that most of the changes that have taken place with container design have been associated with the "integral" container rather than the central ship refrigeration systems that are popular on the long haul trade routes.

The integral container is one which has refrigeration equipment within the ISO standard length.

Secondly product changes have occurred, especially with the packaging systems used to carry products within the transport module.

These two functions of equipment and product (including packaging) have to be carefully balanced if successful transportation of cargo is to be accomplished.

CONTAINER ENGINEERING DEVELOPMENT

Several functions of the marine container have under gone considerable development during the last 5 - 8 years,

Some of these areas of development are briefly mentioned below with reference to the following sketch attached as Appendix 1.

1. Insulation

Improved polyurethane foamed in place application techniques have encouraged reductions in insulation thickness to improve cargo volume capacity. Insulation reduction from a temperature point of view can be balanced with increased refrigeration capacity, however decreased insulation efficiency also decreases relative humidity performance and can cause weight loss in horticultural products.

2. TransFRESH Door Seal

Flexible Door Curtain can be fitted to eliminate air leakage at doors and must be used when providing controlled or modified atmospheres.

3. Floors

High strength raised floors enable bottom air delivery systems to create improved air and temperature distribution characteristics. Floors should extend the full width of the container to stop pallets tipping. Floor drains have been eliminated in most containers operating from New Zealand and Australia.

4. Side Walls

Seam welded stainless steel linings are now used for strength and cleanliness. However the deletion of side wall battens which has become common practice can cause some difficulties with maintaining air flow and temperature distribution when cargo is in close contact with the side walls in high ambient

temperature conditions.

5. Temperature Control

Constant delivery air temperature control is now accepted as the most suitable system for carrying chilled cargo. This development has taken place within the last 5 years and is now widely accepted by most carriers. Some designs however continue to measure return air temperature whilst delivery air temperature is being controlled. This can create some confusion when interpreting temperature charts for cargo claims.

6. Air Volume

Circulated air volumes can now be as high as 100 air changes per hour. Ten years ago 40 air changes per hour was normal. Whilst this gives improved temperature gradients throughout the cargo problems are created due to the increased energy required to distribute the air and also the possibility of dehydrating cargo that is not suitably protected from weight loss by good packaging design. Fresh air entering the container can now be controlled from as much as two air changes per hour down to zero.

7. Forced Air Flow

Air flow fans now force air through evaporators rather than inducing the air flow. This ensures that heat energy produced by the fans and dissipated to the air flow is removed by the refrigeration unit before the increased

temperature and lower relative humidity affects the cargo.

8. Capacity Control

Systems now provide constant and accurate temperature control by accurately modulating the capacity of the refrigeration unit. This system, whilst providing good temperature performance is energy intensive and is currently attracting the attention of design engineers.

9. Atmospheres

The provision of gas charging ports by TransFRESH enables air to be replaced with a pre-determined mixture of oxygen, carbon dioxide, nitrogen and sometimes carbon monoxide to improve quality and life of horticultural products.

10. Atmosphere Controller

Recent development enables the gas mixtures established in 9 above to be monitored and controlled throughout the journey.

11. CO2 Remover

Part of the TransFRESH atmosphere system enables CO2 to be removed throughout the journey.

PRODUCT/PACKAGING DEVELOPMENTS

Perhaps the most spectacular changes that will occur in the future will be associated with the development of hybrid varieties with improved post harvest life characteristics.

With reference to Appendix 2 the following comments are made

concerning factors associated with the cargo and its packaging system that influence successful carriage of perishable cargoes.

1. Product

- 1.1 Product Variety Selection
- 1.2 Harvesting Techniques
- 1.3 Grading Methods and Standards
- 1.4 Package Filling Techniques

2. Inner Package Design

- 2.1 Weight Loss Control through Barrier Film, or waxing
- 2.2 Temperature Control
 - a) Pre Cooling
 - b) Storage and Transport
- 2.3 Gas Exchange
- 2.4 Strength and product protection
- 2.5 Aesthetics

3. Palletising

- 3.1 Pallet Size to Suit Inside Container Dimensions
- 3.2 Pallet Assembly with Jigs, Strapping etc
- 3.3 Pre Cooling - Normally Horizontal Air Flow
- 3.4 Storage - Various Air Flow Characteristics
- 3.5 Transport - Vertical Air Flow
- 3.6 Shipper Temperature monitoring measuring Fruit or Air Temperature

ACHIEVEMENTS

TransFRESH Pacific Ltd., operating from its New Zealand base and more recently from its base in Melbourne Australia have now

completed in excess of 100 separate container shipments of cargo where control has been maintained over temperature, oxygen and carbon dioxide.

Commodities carried have included the following:

Apples -Coxs apples usually carried between New Zealand and the United Kingdom under regular refrigeration from late February normally maintain quality until the end of the 2nd week in May.

When transported under controlled atmospheres and stored under controlled atmospheres in the United Kingdom following arrival this apple has been sold until the middle of July.

Melons - special and delicate varieties of melon, grown specifically for the Japanese market, have been restricted to transportation by airfreight. Last year it was shown that shipments can be made by sea using controlled atmospheres with more than acceptable results, especially when taking account of the increased volume that can be shipped by sea at reduced transport costs when compared to airfreight.

Blueberries - For two seasons fresh New Zealand blueberries have been shipped to the West Coast of the United States of America by sea experiencing a 19 day in container time. The shipments have been successfully marketed following arrival.

Pears - Australian pears transported to many markets often suffer from early yellowing and softening under normal refrigeration. An initial container of Australian William Pears was carried between Melbourne and Los Angeles last season with the product arriving in firm green condition giving the importer improved opportunities for maximising price and marketing capabilities.'

Avocados - Avocados were carried by sea under controlled atmospheres last season between New Zealand and Australia in preparation for shipment by sea to Japan in 1986/87. Apart from responding well to controlled atmospheres avocados experience an added benefit from atmospheres by virtue of a depression in chilling injury temperature which enables the carriage temperature to be maintained much closer to the optimum level.

Stonefruit - Nectarines have been carried to the West Coast of the United States of America from New Zealand by sea freight under controlled atmospheres with impressive results. During the coming season when production volumes are expected to be high, this system of distribution is expected to be widely utilised between New Zealand and Australia and markets in America, South East Asia and the Middle East.

Asparagus - Fresh asparagus has been shipped between New Zealand and Japan by sea in controlled atmospheres. Whilst the product suffers from a short shelf life after discharge

from the container the product arrived in Japan in very good condition. An added benefit was recognised with these shipments in terms of the 100% mortality rate of mites and thrips which normally requires this product to be fumigated on arrival in Japan.

CONCLUSION

Recent engineering developments in container environmental design must be balanced with well managed post harvest techniques and properly designed packaging systems. If this is done considerable improvements could be made on the overall efficiency of transporting perishable products throughout the world.

J. R. LOVEGROVE

The Shipping Corporation of New Zealand Ltd

September 1986

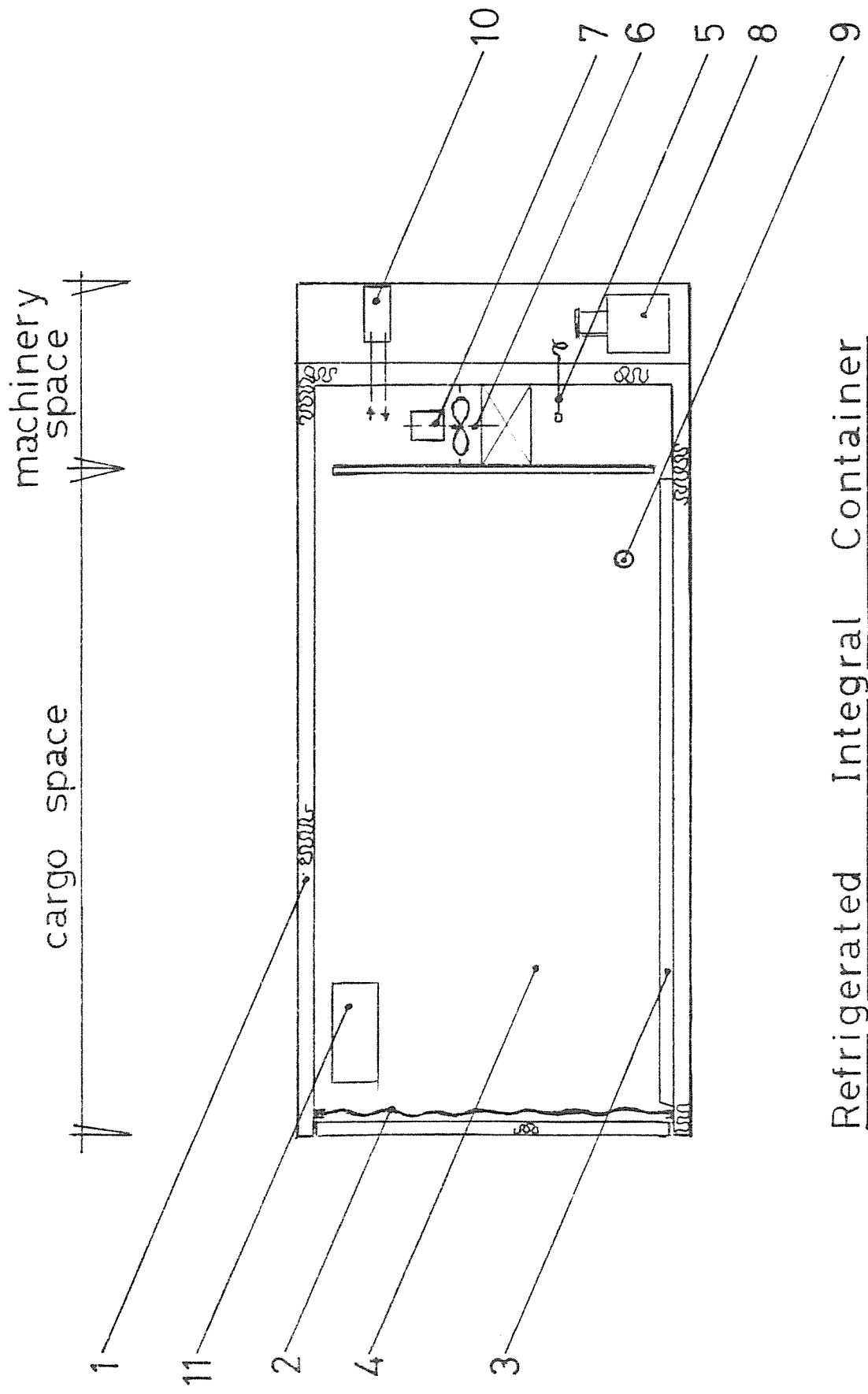

Refrigerated Integral Container

Development Areas

APPENDIX 1

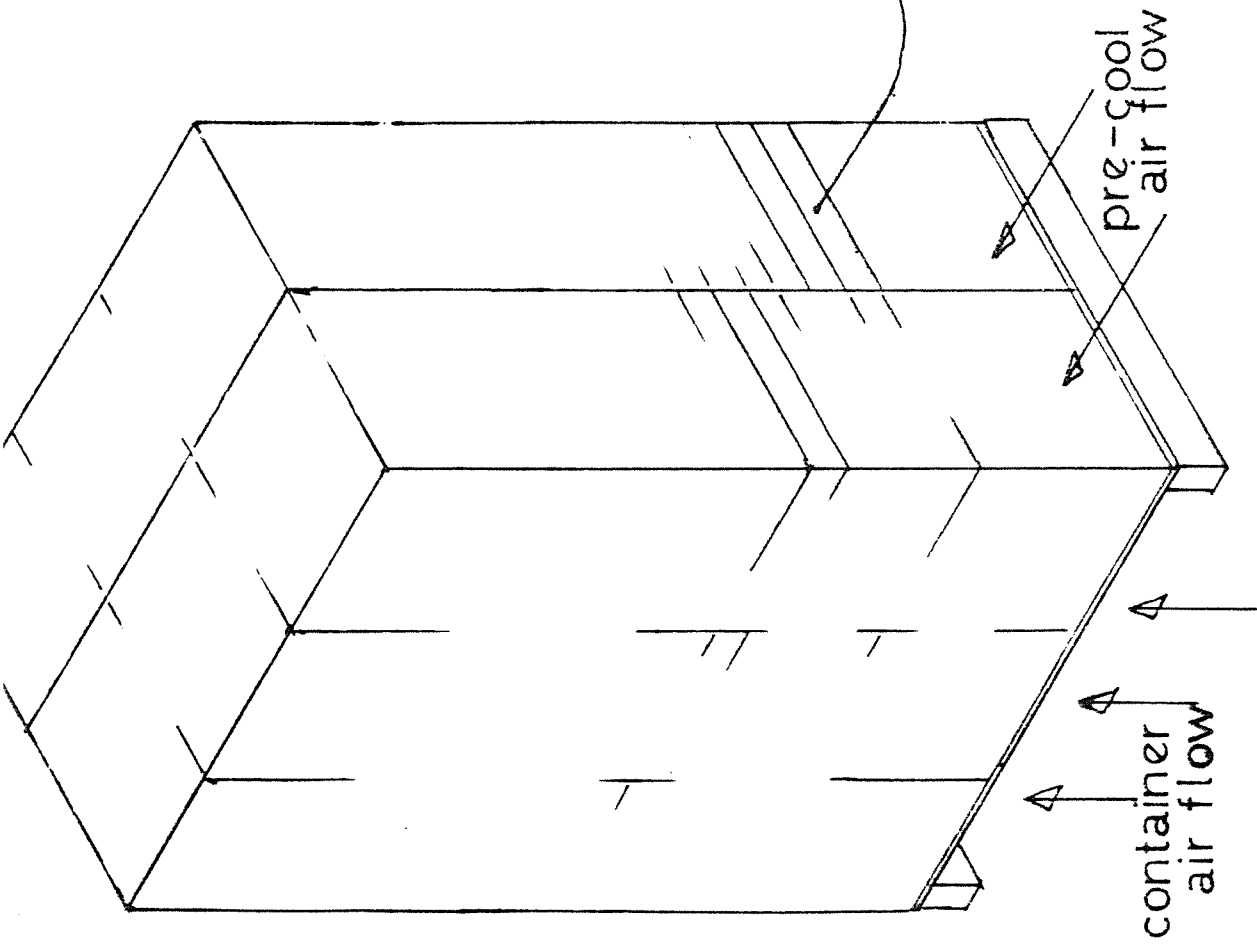

Pallet Assembly

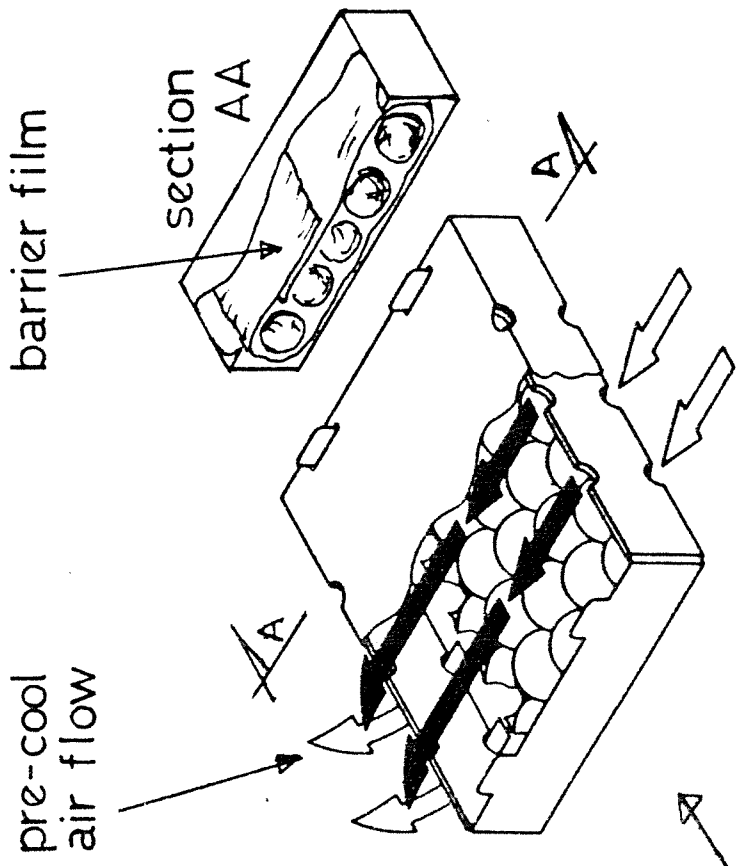

Inner Package Design

Packaging Developments

APPENDIX 2